

GREYSTONE ENERGY SYSTEMS INC

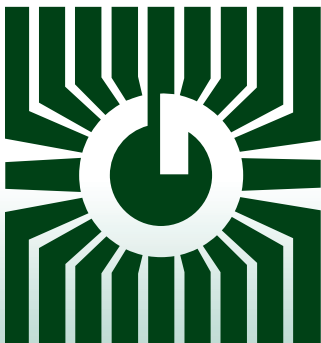

REGULATED DC POWER SUPPLIES PS Series

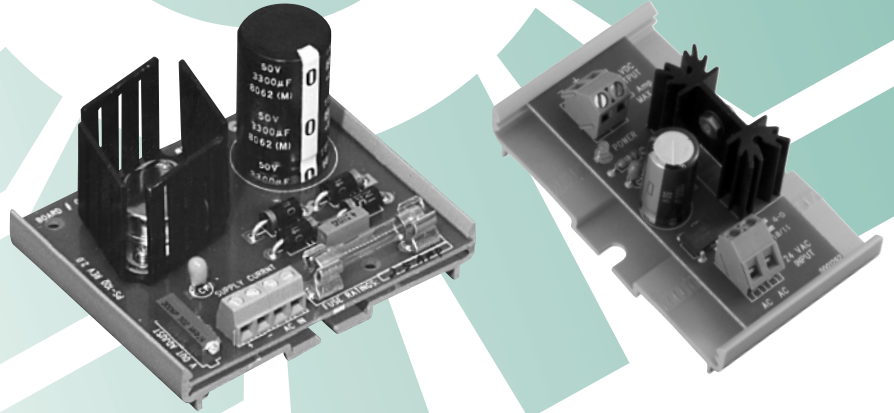

Precision power supplies

FEATURES:

- 24 VAC input/DC output
- Adjustable/fixed voltage output
- Full or half wave rectified
- Snap track mounted
- Over-current protected

*Peace of mind
through reliable
power supplies*

GREYSTONE HAS AN ISO 9001 REGISTERED QUALITY SYSTEM

SPECIFICATIONS:

MODEL	PS1X0X	PS124F
Input Voltage	5 - 30 Vac	24 Vac \pm 10%, 50/60 Hz
Output Voltage	Factory set to 24 Vdc, Field Adjustable 2 - 27 Vdc	24 Vdc, Fixed (full wave rectified)
Output Current: (max)	1.5A (PS1001) and (PS1101) 3.0A (PS1003) and (PS1103)	0.5 amp maximum (0-40 °C) 0.35 amp max (40-50 °C)
Supply Regulation	2%	1% at full-rated current
Overcurrent Protection	2.5A Fuse (PS1001) and (PS1101) 5.0A Fuse (PS1003) and (PS1103)	Regulated thermal shutdown
Operating Temperature	0° - 70°C (32° - 158°F)	0° - 50°C (32° - 122°F)
Dimensions: L x W x H	82 mm x 69 mm x 48 mm (3.25" x 2.75" x 1.90")	82 mm x 32 mm x 28 mm (3.25" x 1.26" x 1.1")

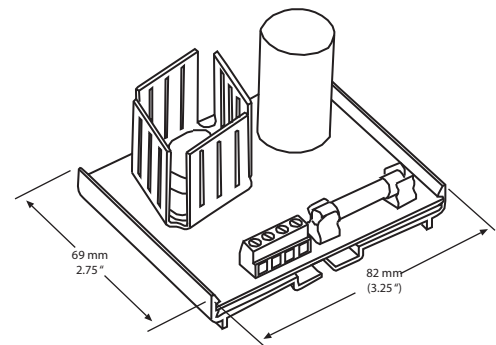
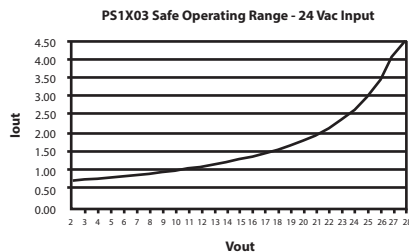
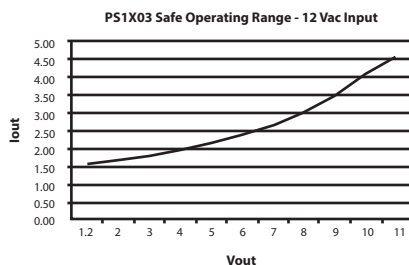
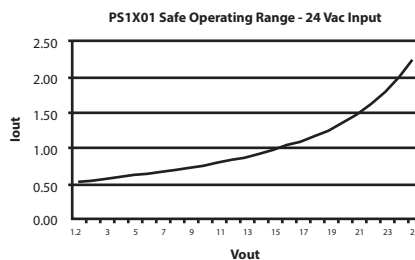
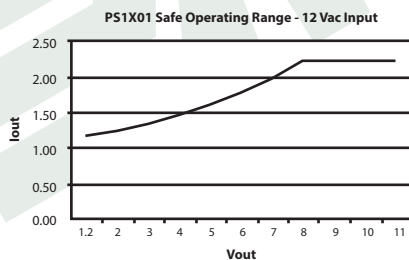

PS1X0

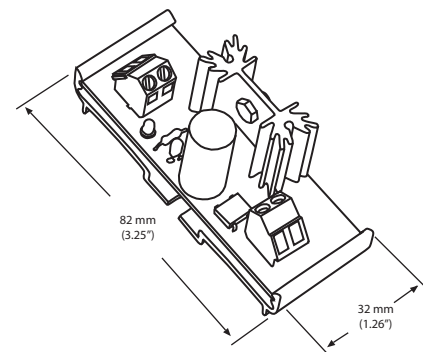

PS124F

PRODUCT ORDERING INFORMATION

<input type="checkbox"/> PS1001	24 Vac/24 Vdc @ 1.5 Amps, Adjustable full wave rectified
<input type="checkbox"/> PS1101	24 Vac/24 Vdc @ 1.5 Amps, Adjustable half wave rectified
<input type="checkbox"/> PS1003	24 Vac/24 Vdc @ 3.0 Amps, Adjustable full wave rectified
<input type="checkbox"/> PS1103	24 Vac/24 Vdc @ 3.0 Amps, Adjustable half wave rectified
<input type="checkbox"/> PS124F	24 Vac/24 Vdc @ 0.5 Amps, Fixed, full wave rectified



GREYSTONE

ENERGY SYSTEMS INC

Greystone Energy Systems, Inc.
150 English Drive, Moncton,
New Brunswick, Canada E1E 4G7

(506) 853-3057 Fax: (506) 853-6014
North America: 1-800-561-5611
e-mail: mail@greystoneenergy.com
www.greystoneenergy.com

RoHS
COMPLIANT



Greystone Energy Systems Inc. is one of North America's largest ISO registered manufacturers of HVAC/R sensors and transmitters for Building Automation Management Systems.

We have conscientiously established a worldwide reputation as an industry leader by maintaining leading-edge design technology, prompt technical support, and a commitment to on-time deliveries. We take pride in our Quality Management System which is ISO 9001 certified, assuring our customers of consistent product reliability.

GREYSTONE HAS AN **ISO 9001** REGISTERED QUALITY SYSTEM